

NOTE: 1
 DESIGN CODE:
 NS-EN 13445

NOTE: 2
 TECHNICAL CLASSIFICATION:
 Article Type: 003-Valve Stabs
 Main Group: 3.03. Ø55-Valvestab
 Intermediate Group: 3.12.2. Receptacle
 Sub Group: 3.12.69.2. Dual

NOTE: 3
 INTERFACE INFORMATION:
 Pressure Rating Bar: 250
 Material: Intervention
 Weight: 7 kg
 Volume: 1,72 dm³
 Surface Area: 3501 cm²
 Hydraulic: 1/2" BSP
 Mechanical: N/A
 Electrical: N/A
 Com. & Protocol: N/A

NOTE: 4
 SPAREPARTS:
 BB1690

NOTE: 5
 ADDITIONAL INFORMATION:
 Usermanual: 600112-TD-0003

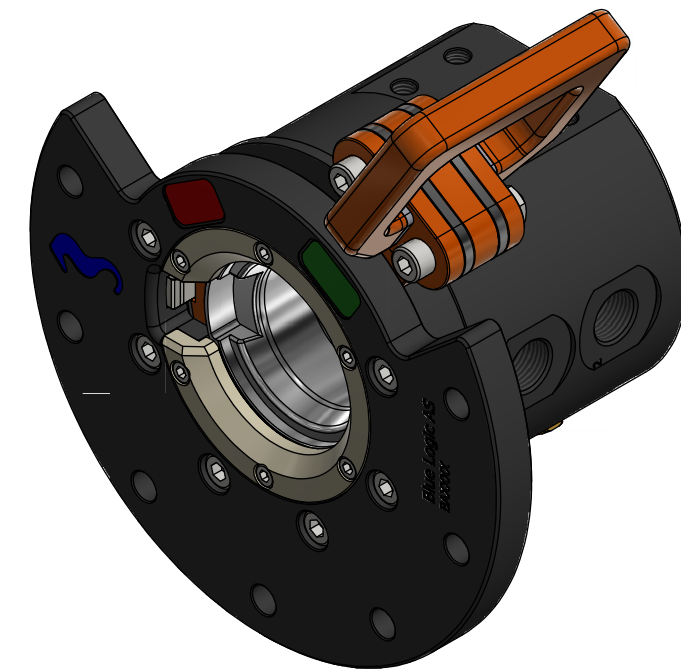
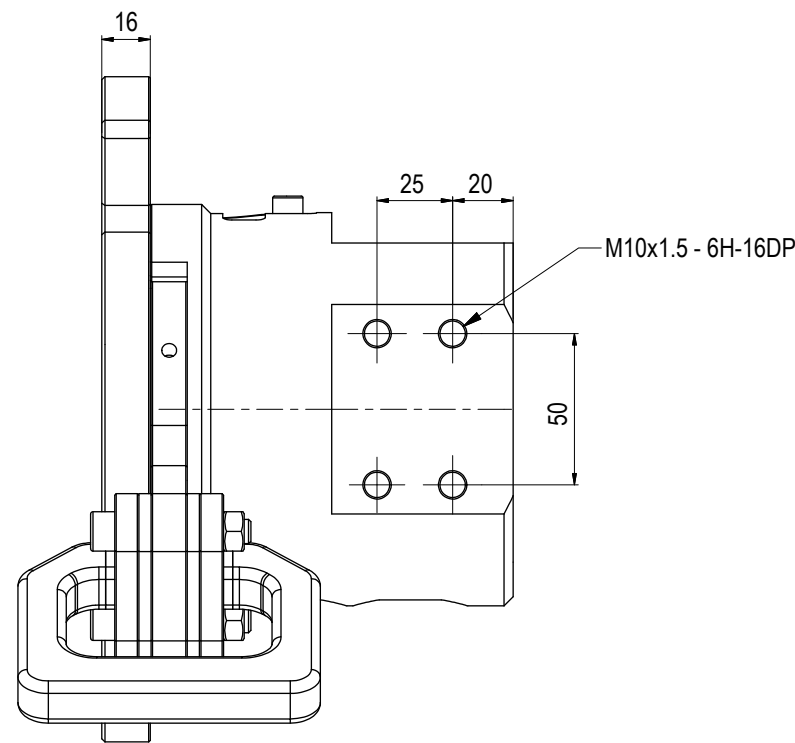
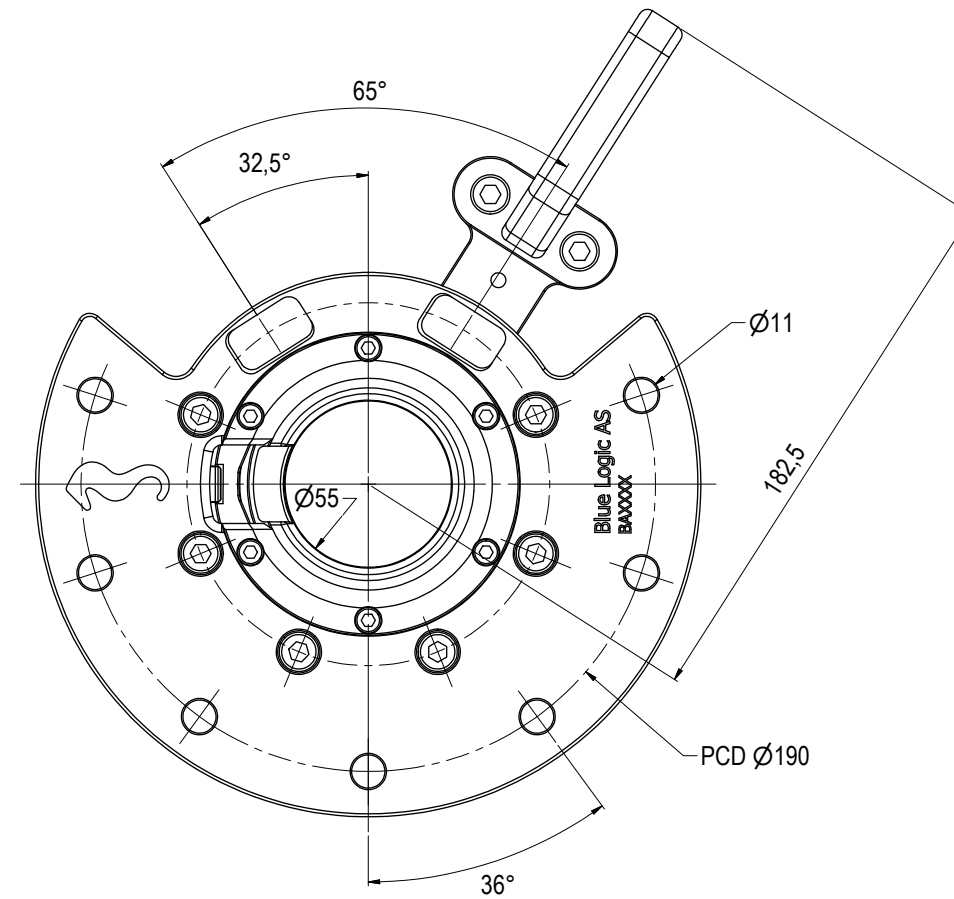
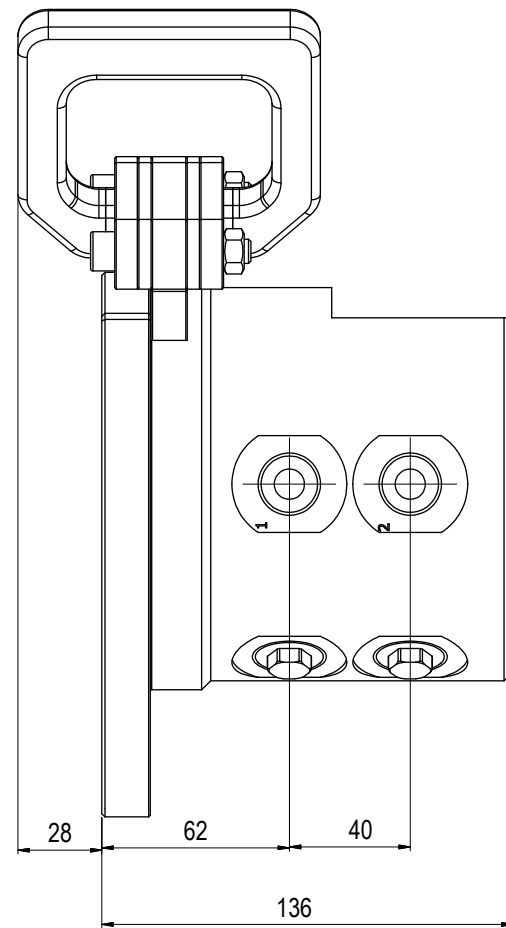
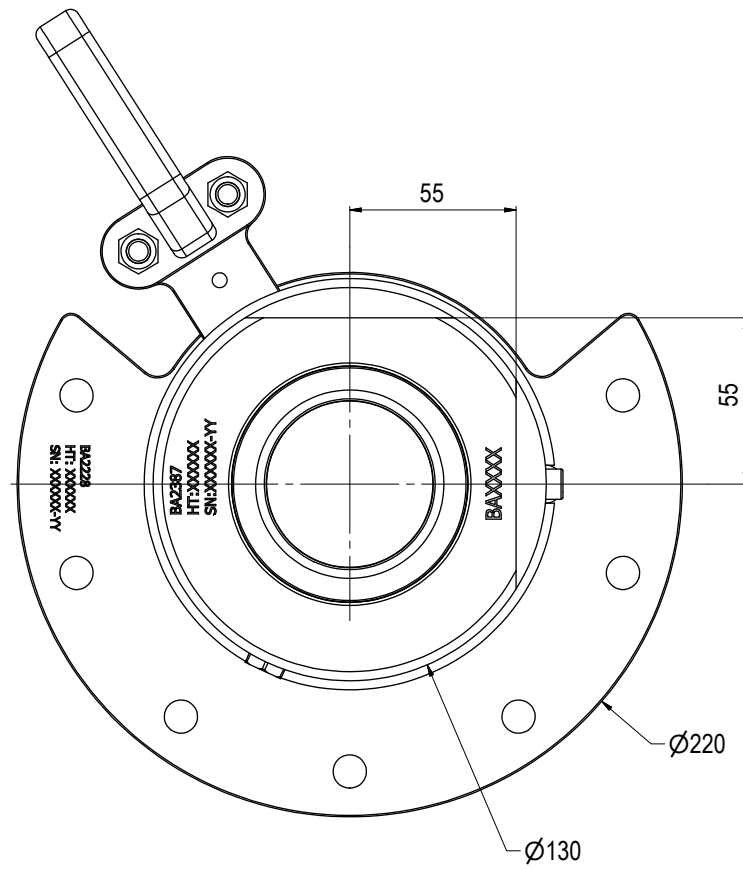

05	15.8.2016	2-IFT (Issued for Tender)		WTJ	LGH	WTJ
04	16.12.2015	2-IFT (Issued for Tender)		WTJ	HNJ	WTJ
03	24.10.2014	2-IFT (Issued for Tender)		LGH	NA	NA
02	19.6.2014	2-IFT (Issued for Tender)		WTJ	HNJ	WTJ
Rev.	Date	Reason for issue	Revision change	Made	Chk'd	Appr.



Dwg Scale:	NTS
Dwg Proj:	
Dwg Format:	A3

Drawing title:	Ø55 DP VStab Rec 250Bar Interv Man BSP 1/2" with Flange
Drawing number:	BA2386
Rev.	05